

Technical data sheet

All right reserved Landa illuminotecnica S.p.A.
will reserve to change the specific note without
any written notice.

LANDA[®]
illuminotecnica

Kubs 120

Article 404LS4X2H
Product type: Wall
Body material: Die-casting aluminium EN47100 and extruded aluminium AW 6060, prior the painting process, washed with stones. Painting made by polyester powder with high resistant against oxidation.
Transparent polycarbonate UV protection. PVC and EPDM 50Sh gaskets
Reflectors in polycarbonate; BEAM 10°
Screws in A2 stainless steel
Colours available: Graphite and Oxide
Driver included: GE LIGHTEC 350MA Dimmable: NO

IK07

IP65

850°C

Powered by

Citizen Electronics CLL104 3000°K

2x4W 2x305LM Beam 10°

(On request 5000°K)

Transformer Included

GE LIGHTEC 350 mA

IP67 220/240V

www.landa.it



Colours available:

Graphite



Oxide

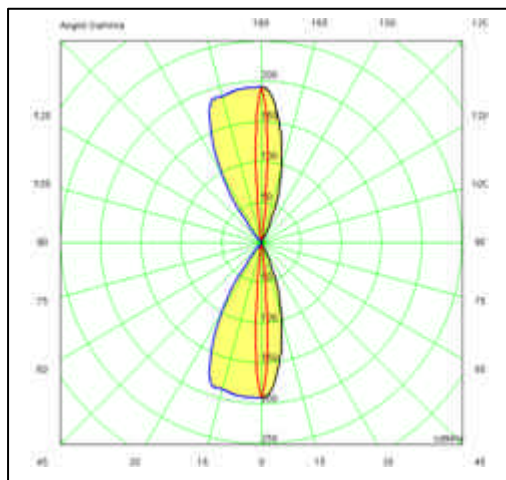
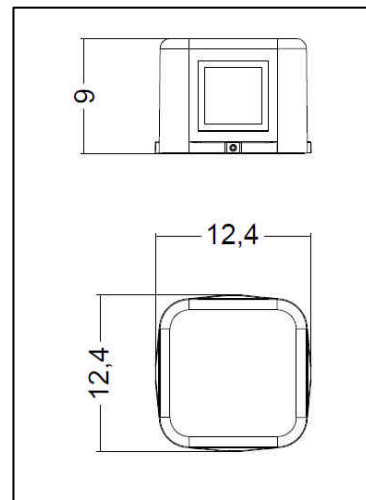

Light effects:

