

Technical data sheet

All right reserved Landa illuminotecnica S.p.A.
will reserve to change the specific note without
any written notice.

LANDA[®]
illuminotecnica

Flute

Article 550VH70
Product type: Projector
Body material Die-casting aluminium EN47100, prior the painting process, washed with stones. Painting made by polyester powder with high resistant against oxidation. Ring in die-casting aluminium EN47100
Tempered glass diffuser in transparent finish 10mm thick and silicon gasket.
Reflector in aluminium anodized.
Screws in A2 stainless steel
Tridonic Electronic Ballast

IK10
IP65
850°C
RX7s 70W 240V Metalhalide

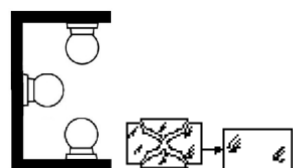

Colours available:

Graphite



nhg

Metalgrey



all

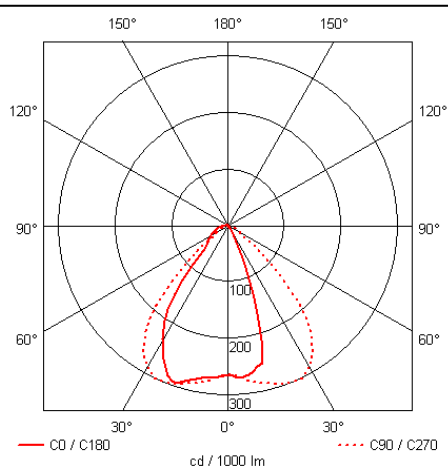
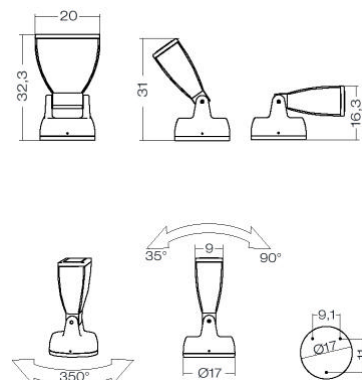

Accessories:

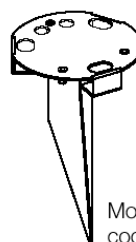

Mounting spike
code **00A550P**

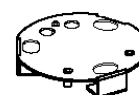

Mounting plate
code **00A550R**