



Outdoor lamp | Lampe d'extérieur

Material: stainless steel, celoron, aluminium, borosilicate glass, galvanized steel, silicone seals

Matériaux: acier inoxydable, celoron, aluminium, verre borosilicate, acier galvanisé, joints silicone

Outdoor painting
Peinture haute resistance

Weight: Net 7 kg | Gross 8,4 kg
Poids: Net 7 kg | Brut 8,4 kg

Dimensions:
Rod: 370 mm | Cast: Ø143 mm |
Arm: 620 mm
Bielle: 370 mm | Fonte: Ø143 mm
| Bras: 620 mm

Packaging: 1500 × 260 × 265 mm

Rubber electric wire H07RN-F
3 × 1 mm²
Câble électrique caoutchouc
H07RN-F 3 × 1 mm²

Anti-theft screws
Vis antivol

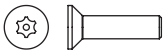

CL I - E27 - ESL 23W / Led 8W

IP 64    

DCW
ÉDITIONS
PARIS

71 rue de la Fontaine au Roi
75011 Paris - France
+33 (0)1 40 21 37 60
sales@dcwe.fr

8 800 301-72-50
<http://lampshopping.ru>

TECHNICAL SHEET / FICHE TECHNIQUE

LAMPE GRAS N°304 XL 90 OUTDOOR

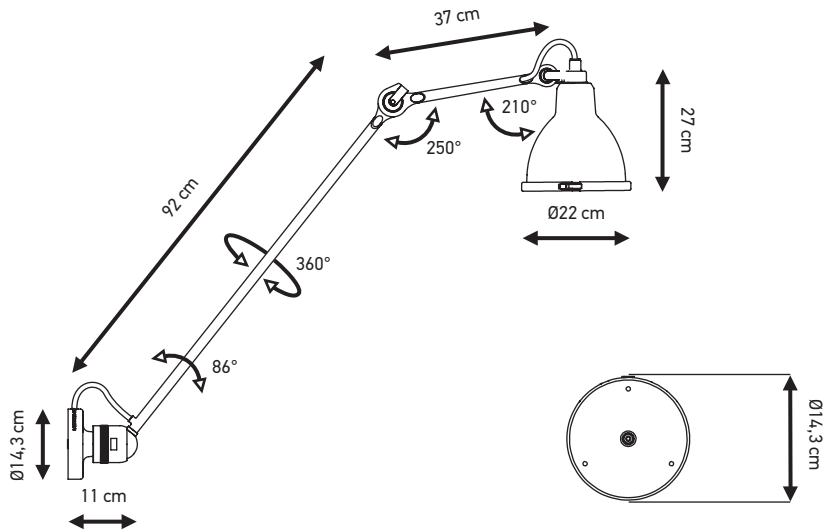

FINISHES / FINITIONS



N°304 XL 90 BL-SAT

Black satin steel | Colored or coppered shade
Acier noir satin | Réflecteur couleur ou cuivré

IN THE BOX / CONTENU

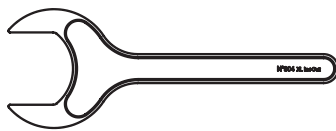

×1

SHADES COLOURS / COULEURS DE RÉFLECTEURS



black



red



yellow



blue



raw
copper



raw
copper
white

The shades are available in round or conic shape / Les réflecteurs sont disponibles en version ronde ou conique

